

Why Is Rod Coating Still Around?

As a freshman in college the author had a great idea for a term paper: Coating rods. The only problem was that there was no information available at the college library so a couple of Saturdays were spent at the main library on 5th and 42nd in New York City. References to wire wound rods being used in Germany in the 1880's were found. 120 years ago! In the 1880's inventions included: the bicycle, the electric chair, the typewriter and George Eastman made and sold the first inexpensive "Kodak" (camera). Fast forward to 1912 and Rochester, NY where Charles Mayer patented a rod coater and began to popularize rod coating. Still almost 100 years ago. At a TAPPI tour of an Eastman Kodak paper mill it was noticed that almost every paper person would stop at the scrap barrel and be very impressed almost amazed by the superior quality of the paper. That was followed by the explanation that this machine was purchased used in 1928 by George Eastman. It still turns out photo quality paper today. And, there are a number of 78" Mayer Machines still out there.

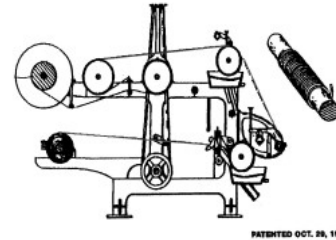

C.W. Mayer Coating Machine

So why is a technology that's over 100 years old still around? Why is this method still used by over 60% of coaters? Why is it still turning out the best quality window film, litho plates, protective tapes and release papers at a reasonable cost? Maybe that's the answer. Rod coating continues to deliver a smooth, accurate and repeatable coating at a reasonable cost. Rod coating additionally offers very quick coat weight changes. In less than a minute wet film thickness can be changed from 4.5 microns (.00018") to 380 microns (.015") or anything in between.

The rod has been referred to as a coating rod, metering rod, equalizer rod, doctor rod, the tongue twister wire wound rod and every conceivable way of spelling and pronouncing Mayer. This paper will show how the rod works, the different types available and some tips on how to get the best performance out of rod coating.

Smooth Rods The traditional rod is wire wound but there are also a number of plain or smooth rods being used. They are referred to in many different ways.

They are usually chrome plated or ceramic coated. With a smooth rod the coat weight is changed by either changing the pressure of the rod against the web or by changing the solids content of the solution. One example of this is a Kohler type (diagram to the right) where the rod is pushed up against a backing roll by the air bladder under the rod bed.

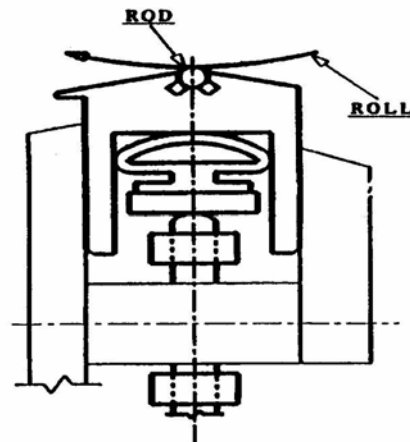

How It Works

Spreading butter with a serrated edge knife has always been a good analogy that helps explain how a wire wound or formed rod works. The butter squeezes between the substrate and the cavities between the wire that's wrapped around the rod and comes out in little hills and valleys and then flows out smooth. (If the butter is warm)

If we could look at a cross section of hard butter, we'd see something like the figure to the right. Each hill has an area of .000061 square inches. This is theoretical. What happens in real life is that some of that coating stays in the bottom of the crevice between the wires.

So, if the butter is warm, it flows out and we have a perfectly flat uniform coating. The coating thickness laid down by a rod is roughly 9% of the wire diameter. So, a #10 rod which is .010" or 10 mils, will give you a .9 mil coating. Charts are available that include wet film thickness and dry coat weight. Later we'll talk about that butter we laid down and what happens if it's not warm enough.

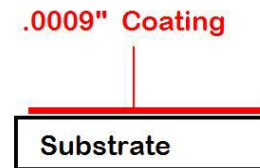
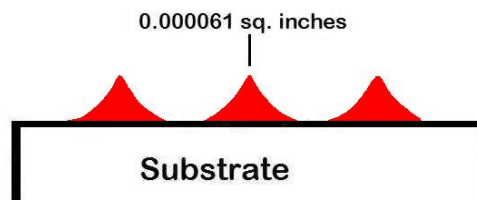
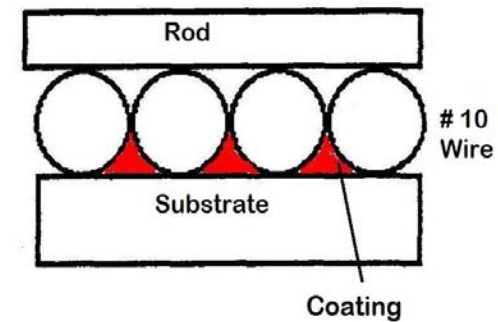

Coating Heads

Now that we know how the rod works, we'll learn how to get that coating on the web. The following drawing is a typical Kiss Roll configuration. Here the web is moving from left to right. The pan is filled with coating so that the pick up or application roll is rotated against the web to deposit the coating on the web. The "lifter fingers" are also known as edge deckles and are metal or plastic and used to lift the web away from the roller and keep the edge of the web clean as the rod, because of its helical winding, spreads the coating out to one side.

The best arrangement is where the hold down rolls can act independently so the operator can change the wrap around the applicator roll or the rod. The operator will also need to be able to change the direction of the applicator roll.

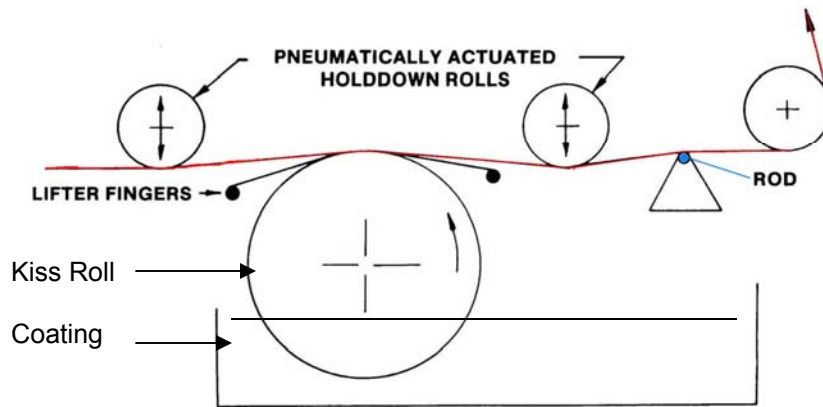

SureFlow Coating Head

This type of coating head combines the applicator and the rod in one unit. The coating is contained by the diagonal coating pan, the web itself and edge dams at either end of the web. This method allows the operator to move the edge dams inward and outward to adjust the width of the coating and the width of clean edges if desired. It's also easy to change from wide to narrow webs just by moving the edge dams in or out. A backing plate keeps the web flat and helps avoid any leaks on the sides. The rod can be moved in and out to be able to adjust the wrap angle. A movable guide can be added above the backing plate to allow for changing the wrap angle on either side of the rod. The coating pan can be covered to limit evaporation. With multiple edge dams this type of coater can do stripped coatings and even lay down different coatings in different thicknesses.

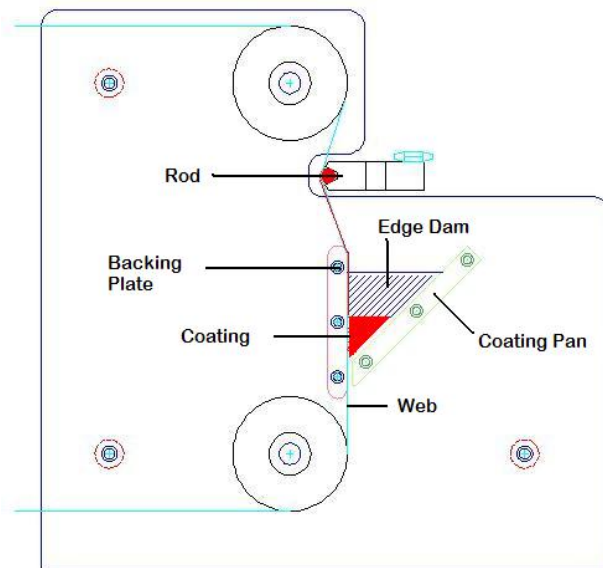

Wrap Angle

There is no ideal wrap angle. But the place to start out is between 10 and 30 degrees. As was already mentioned, the ideal system allows the operator to vary the wrap angle on both the incoming and outgoing side of the rod. When

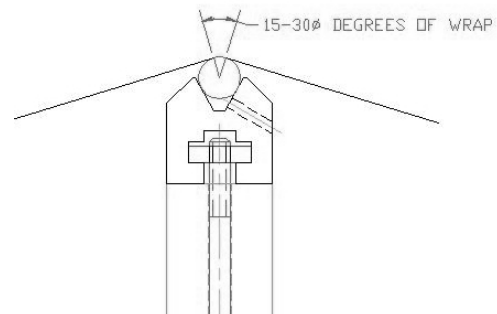

the web is momentarily tensioned between the hold down rolls and the rod, the web smoothens out.

Rod Holders

Running a rod without a holder or rod bed is usually not a good idea. An unsupported rod would have to be of a very large diameter rod to avoid bowing. This would be very expensive and not necessary. In addition, a rod bed wipes the rod so that a clean surface is presented to the coating and the substrate at each revolution of the rod.

Kohler style.

It's usually used with a backing roll. This type encapsulates the rod with about a 200 degree wrap around the rod. It's necessary to hold the rod in place so that it is not pushed out of alignment by the backing roll.

You may notice a channel in yellow below the rod as well as a threaded pipe fitting at the end. The channel runs almost to the end of the holder.

Water or a solvent is pumped through the pipe fitting and under the rod to keep the rod clean while it's running or to keep it clean when the web has stopped so that the coating doesn't harden on the holder and the rod.

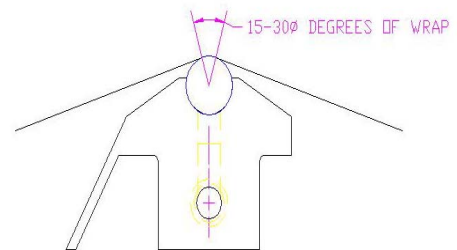

Half Round

This is a half round rod bed. It still holds the rod well and acts to clean the rod so that it presents a clean surface to the web. The downside with this holder and the previous holder is that each rod has to be ground so that the rod with wire or the form will fit in the radius of the rod bed.

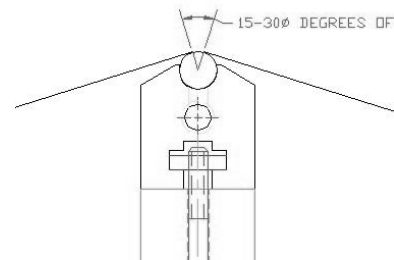

V Type

The traditional rod holder is a "V" type. The V can range from 90 ° down to 60 °. The "V" should accommodate the largest diameter wire and the smallest. The V shape can also accommodate small changes in wire sizes without having to adjust the drive or the rod holder.

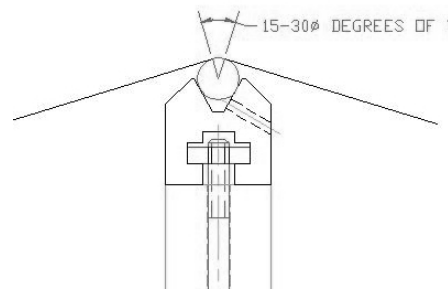

Drives

When a larger wire size rod replaces a smaller wire size, the rod will sit higher in the rod bed and may require readjustment of the drive or rod holder height. A flexible drive or coupler can make life a little easier because it can allow for misalignment in any direction and save having



to make those height adjustments. The bayonet coupling also speeds rod changes. Traditionally a drill chuck coupled to an electric, air or hydraulic motor has been used to drive the rods. However square ends, pins, slots and flats for set screws are not uncommon.

Rod Diameter

Typically rods range from 3/16" diameter up to 1" with the norm being between 1/4" and 5/8". The question of what's the best diameter comes up often. Fords and Chevys both accomplish the same task and are quite similar, but some people prefer one over the other. Operators at two different locations of the same company will often scratch their heads wondering why the other guys use a different diameter rod. It really doesn't matter because the wire does the metering. The small difference in rod radius and contact arc can be compensated for by a slight adjustment in the wrap angle.

Wire Wound Rod

This is your basic wire wound rod. The base rod is typically made of Stainless Steel. In very few cases carbon steel can be used if corrosion will not contaminate

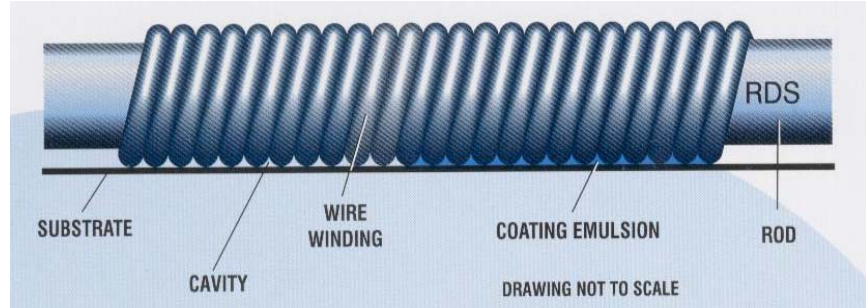

the coating. Type 416 Stainless has fair corrosion resistance, can be used in magnetic holders and has a price advantage over the 300 series grades. Type 303 is the most common grade for the base rod. It offers very good corrosion resistance that is surpassed by only type 316. Type 316 has superior corrosion resistance but carries an increasing price premium. Wire is almost always type 302 or 304. Type 304 gives better results in smaller sizes.

Formed Rods

The formed rod offers variations from wire. In some cases the radius of the hill and the distance

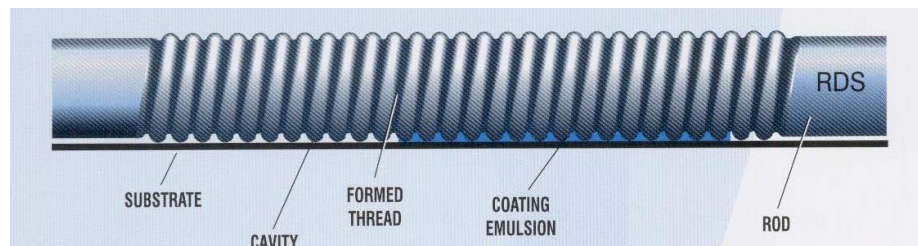

between the tops of the hills can be the same as the equivalent wire wound rod. The shape of the cavity can be customized for different applications. In almost all cases, the valley has a radius instead of a sharp crevice as when two wires meet. Adhesives and other coatings that tend to clog up the rod don't get caught in that wider smoother valley.

Gapped Rod

Winding wire larger than .075" is impractical. One way to provide heavier coat weights and handle high viscosity and high solids coatings is with the gapped rod. Although the wires are very tightly wound on the rod, the gapped rod must be handled more carefully so as not to shift the wires and upset the gap between the wires. If necessary, the wire can be wound into a shallow dent made by the thread rolling die. This is more than enough to secure the wire.

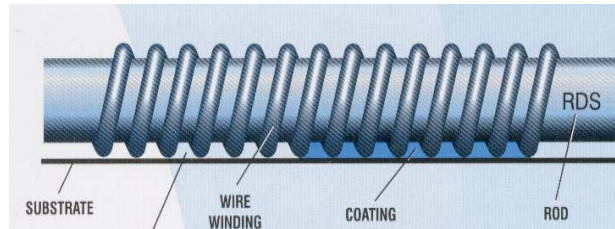

Double Wound

A double wound rod can work with similar coatings. The bottom drawing shows the coating in animated suspension or hard butter form. The top wire sits in the valley of the bottom wire and is inherently secure.

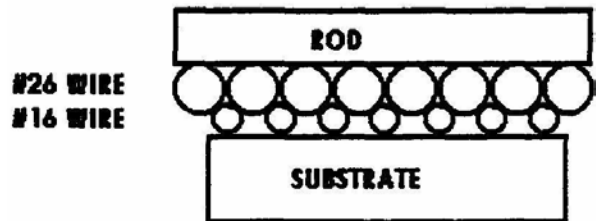

The gapped rod has more possible combinations where the double wound rod is limited to the top wire being about 1/2 of the bottom wire.

With rod coating you can apply a wet coating as thin as .19 mils up to as thick as 15 mils.



Substrates

Paper, Film, Foils, Rubber, Paperboard, Aluminum sheet and lithograph plates. The limitation seems to be imagination and web handling equipment.

Coatings

Just about anything as long as it will flow. In terms of butter, it just has to be warm enough. Flow properties are more important than viscosity. Very viscous coatings can be applied and metered without a backing roll because the coating has good flow properties.

Speed

The range is all encompassing. From 50 Feet Per Hour to 3000 Feet Per Minute for Speedsizers on paper machines. In most cases, coating speed is limited by drying capacity or other equipment. Sizing machines are always getting faster. Just like automobile tires, the web can hydroplane. Once this happens, as it goes faster, coat weight will increase.

Drying

Depending on the rheology of the coating, it may need time to flow out so at least a 4 zone dryer is recommended.

Accuracy

Actually coat weight is dependent on the substrate. When coating kraft paper with a curtain coater the coat weight would be exact because only what came out of the slot would be left on the paper. However, the results may not be acceptable because the paper would absorb the coating inconsistently.

A rod can achieve a smooth surface even though the coat weight may be inconsistent. In everyday practice, on aluminum, rods apply coat weights varying by less than .1% .

What's Important?

It's best to start out with uniform materials. That applies to the properties of the web and the coating.

One of the nice things about the rod is that when the web is momentarily tensioned between the hold down rolls and the rod the web smoothens out so, put tension control at the top of the list.

Flow properties can be more important than viscosity. Surface tension can be modified with surfactants.

Use the smallest filter you can get away with.

Have the ability to adjust rod speed and direction as well as the wrap angle on either side of the rod.

Rod Speed

The main reason for turning the rod is to present a clean surface to the coating and substrate and to avoid uneven wear. Start by turning the rod fairly slow, only 25 to 50 rpm then experiment to see if anything faster improves the coating surface and take notes.

Rod Direction

The ability to change rod direction is necessary. In most cases the rod will turn against the web so it can "scrape off" the excess coating. However, lighter coat weights may benefit from running the rod with the web.

Rod Life Expectancy

There are two ways to kill a rod, one is to wear it down with an abrasive coating; the other is to clog the valley between the wires so it reduces coat weight or leaves streaks. When rods clog with dried coating, the best thing to do is soak the rod in which ever solvent works best as soon as it comes off the machine. The rod can be cleaned with a brass wire brush. The practical aspect is deciding how much time should be spent cleaning a \$20 rod. Last but not least, careful handling and storage can't be stressed enough.

Hard Chrome Plating

Stainless Wire has a hardness of about 30 on the Rockwell C scale. Hard Chrome .00025" thick is 68. Chrome can add more than 7 times the life expectancy of a rod depending on how thick the chrome plating. .001" is typical maximum plating thickness. Chrome also adds some lubricity which helps in wet out. Thin applications of chrome (.00025") won't change the coat weight.

Flaws & Causes

Cross direction

If you have a cross direction flaw that repeats uniformly and just happens to match the ratio of rod rotations to the speed of the web it's probably caused by a lengthwise scratch in the wire.



Machine direction Heavier streaks

If you have a flaw in the machine direction that shows up as a heavier or darker coating, either in a solid line or a repeating pattern, it's probably a skip or gap between the wires.

If the flaw is less obvious but still noticeable, it may be a variation in the overall diameter of the rod.

The wire may be oval instead of round. As the wire turns over, the diameter changes and your coating changes.

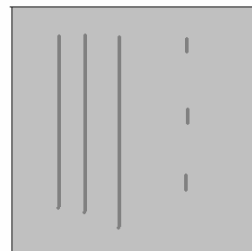

Machine direction Lighter streaks.

If you have a flaw in the machine direction that shows up as a lighter coating it's less likely that there's a bump in the wire.

More likely, is foreign material or some dried coating in the valley between the wires.



What's Important

So, to review: In order to get the most out of your rod coating station, think of Tension, Flow, Filter, Fiddle.

Maintain an even tension.

Pay close attention to viscosity but more importantly flow properties.

Filter your coating to remove any contaminants or dried coating.

Fiddle, with rod speed, direction and wrap angle on either side of the rod.

So, we should have found a reason or two as to why rod coating has been around so long and why it's still popular. Accuracy, Repeatability, Quick Coat Weight Changes and Reasonable Cost.

Referring to the ability to quickly change coatings and coat weights, a window film producer was overheard to say "With over 200 different products to make, we can't use anything but rods."

Bibliography

Greer, Richard., CEMA Proceedings, Fundamentals of Rod, Air Knife and Blade Coaters March 1991

Booth, G.L. Coating Equipment and Processes, Lockwood Press, 1970